

OTAC-PH5 H01A

4G (LTE) remote control
Webasto och Eberspächer

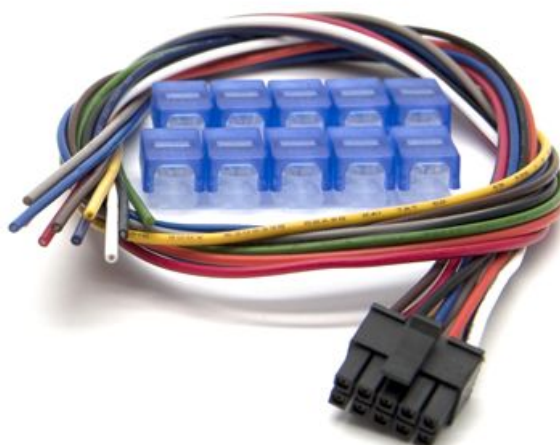

| | |
|-------------------------|--------------------------|
| Document Title: | otac_ph5_h01a_eng_manual |
| Document Version: | 1.01 |
| Document Date: | 2024-12-04 |
| Document First Edition: | 2022-10-31 |
| For Unit-Firmware: | >= v1.00 |

Table of Contents

| | |
|-------------------------------------|--------------|
| 1. Description | p. 3 |
| 2. Mobile APP | p. 4 |
| 3. Technical specification | p. 5 |
| 4. Declaration of conformity | p. 6 |
| 5. Made in Sweden | p. 7 |
| 6. Warranty | p. 7 |
| 7. Compatability | p. 8 |
| 8. Install SIM-card | p. 9 |
| 9. Installation | p. 10 |
| 10. Outputs and inputs | p. 11 |
| 11. Pushbutton | p. 12 |
| 12. Power on | p. 13 |
| 13. First test | p. 14 |
| 14. Use the APP | p. 15 |
| 15. All commands | p. 16 |
| 16. Support | p. 19 |
| 17. Troubleshooting | p. 19 |

1. Description

OTAC-PH5 makes it possible to control Webasto and Eberspächer heaters over the mobile network (4G) with SMS or web interface*. To make it easier to use the unit with SMS we have a mobile APP available for iPhone and Android smartphones.

A SIM-card is required to use the unit, pre-paid or subscription.

The unit also has inputs for an external pushbutton (sold separately) for manually control and a temperaturesensor (sol separately) to show current temperature. The installation usually takes about 30 minutes if connecting to an existing compatible controller. The unit can also be connected directly to the heater depending on model.

*Prepared for data traffic, requires firmware update.



2. Mobile APP

To make it easier to control the unit with SMS we have a mobile APP for iPhone and Android smartphones. When using the APP you don't need to remember any commands just click on the buttons in the APP to control and setup the unit. It is possible to add multiple units in the APP and switch between them.

You can also rename the buttons that control the relays so you know what is connected.

The APP is available in Appstore and Google Play, search for "**GSMS remote control**".

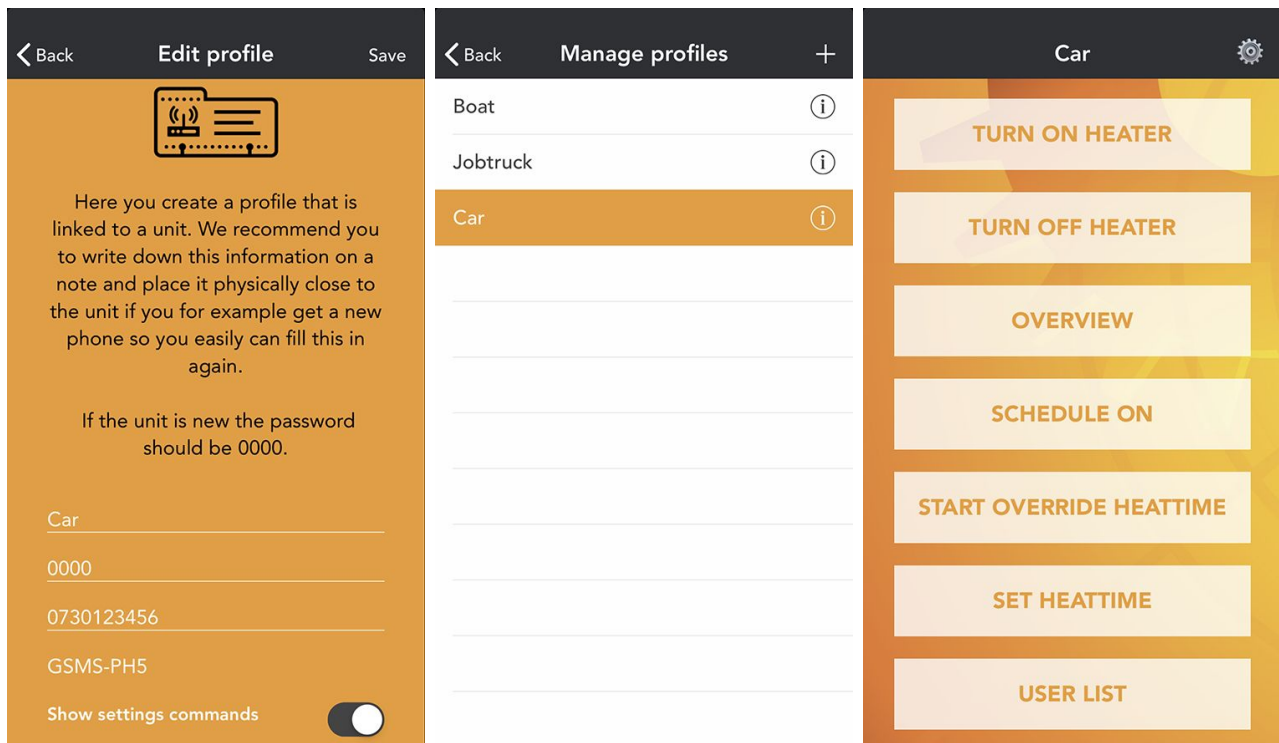

3. Technical specification

| | |
|-------------------------|--|
| Operating voltage: | 12V / 24V |
| Power consumption: | Nominal Idle ~250mW / Max 5W |
| Heattime: | 10 – 999 minutes (default 30min) |
| Dimensions: | 65 x 28 x 80 mm |
| Operating temperature: | -40°C to +80°C |
| Measurable temperature: | -40°C to +105°C |
| Temperature precision: | ± 1°C |
| IP-rating: | IP20 (install inside vehicle cabin) |
| SIM-card type: | Mini-SIM |
| Mobile network: | 4G (LTE) |
| Band | LTE-FDD B1,B3,B5,B7,B8,B20 |
| Modulation: | QPSK, 16QAM |
| Power class: | Klass 3 |

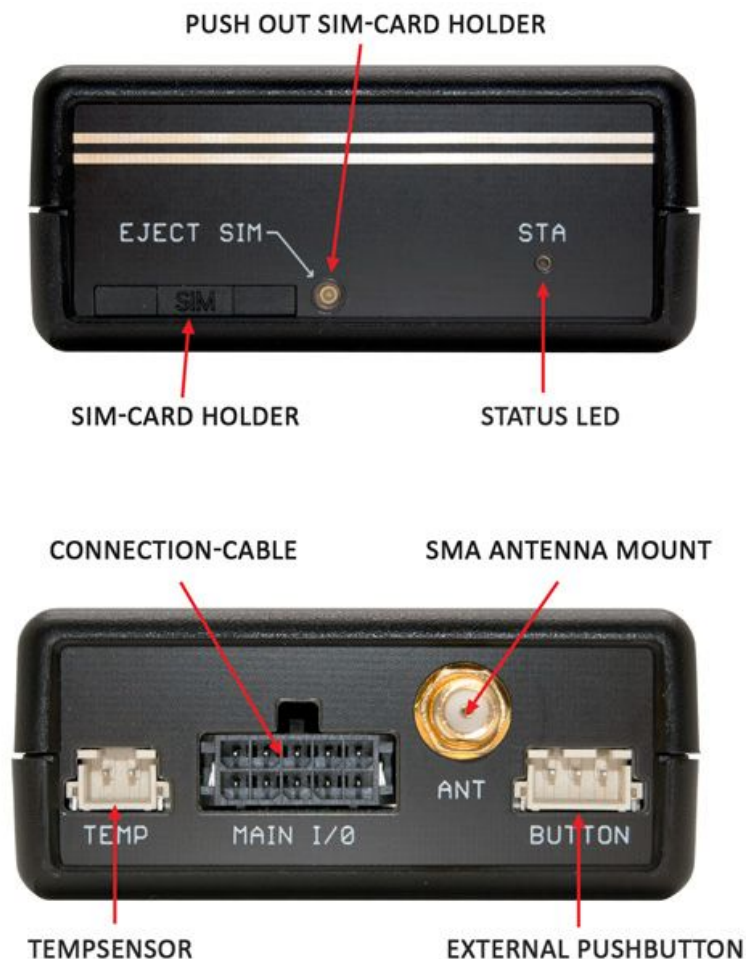

4. Declaration of conformity



This product conforms to the requirements in EU RoHS-directive (2011/65/EU). It does not contain any of the hazardous or forbidden materials described in the directive.

It also complies to EU WEEE- directive (2012/19/EU) and marked with the WEEE label in accordance with directive 2012/19/EU Waste from Electrical and Electronic Equipment.

In addition, Pierr Automatik AB accept scrapped equipment from customers and sort it for waste disposal. Defect equipment returned to Pierr Automatik AB for service may also be scrapped in accordance with the Directive.



Hereby Pierr Automatik AB, Slottsmöllan 16B, 302 31 Halmstad, SWEDEN declares that this product **OTAC-PH5-H01A** comply with the provisions of the following relevant European Union harmonization legislation conformity with the provisions of the EMC Directive (EMCD) 2014/30/EU, Low Voltage Directive (LVD) 2014/35/EU and Radio Equipment Directive (RED) 2014/53/EU according to the following standards.

EN 301 908-1 V15.0.1, EN 301 908-13 V13.1.1 , EN 301 511 V12.5.1, EN 301 489-1 V2.2.3, EN 301 489-52 V1.1.2, EN IEC 62311: 2020, EN 62368-1: 2014+A11:2017

Halmstad, 01/10/2022
Andreas Pierr, CEO

5. Made in Sweden

This product is fully developed and in the following extent made in Sweden.

- PCB* is pick-n-placed and reflow soldered in Sweden.
- Assembled, tested and packaged in Sweden.
- Enclosure is made in China.

*Bare empty PCB is made in China.

Manufacturer:
Pierr Automatik AB
Slottsmöllan 16B
302 31 Halmstad
SWEDEN

PIERR
AUTOMATIK AB

6. Warranty



This products comes with a 2-year warrant. The warranty does not include faults by incorrect usage, incorrect installation, outside circumstances like over voltage due to for example thunder, faults in the 4G (LTE) network, water damage, fire etc.

Warranty does not include changes made to the 4G (LTE) network or other external services regarding for example technical functionality or changed contract terms.

The product will be repaired or replaced with a replacement unit and resent to the customer free of charge if compliance to warranty and provided with purchase documents.

Any charges for removing the unit, travel costs, downtime and other related costs is not covered by the warranty. Return shipping is not covered by warranty and should be paid by the customer.

For this product to work correctly sufficient coverage for the used network 4G (LTE) is required. The unit cannot connect to the network if the coverage is to low.

This product has been developed and manufactured according to the current state of the art and recognized safety standards. It cannot be sure that the product works as intended under all circumstances, at all times and under all conditions.

7. Compatability

This unit is primarily intended for retrofitted heaters. The unit does not support CAN bus and is not suitable for factory-fitted heaters (the heater is controlled via the car's dashboard) but if you have an existing remote control it can still work though. It also has limited support for airheaters and usually cannot control these by itself without an existing compatible controller.

Contact us if you are unsure!

Go here to see all compatible controllers:

https://otacell.se/ph5_compatibility

8. Install SIM-card



There cannot be any PIN code on the SIM-card! If there is a PIN code present first put the card in a mobile phone and **disable** the PIN code in phone settings.



Do not use for example an screwdriver to force out the holder or similiar.

1. Remove the holder by **carefully** push in a clip or similiar in **the hole to the right**.
2. Mount the SIM-card of Mini-SIM size in the holder. It cannot be mounted wrong.
3. Carefully push in the holder again.



9. Installation



This is a universal product that can be used in many applications.
To install the unit you need to have the appropriate knowledge.



Before carrying out any work on a vehicles electrical system it is recommended to disconnect the battery.

With the unit unplugged connect the connection cable (1) as per the separate supplied schematic using the supplied 3M Scotchloks (2).

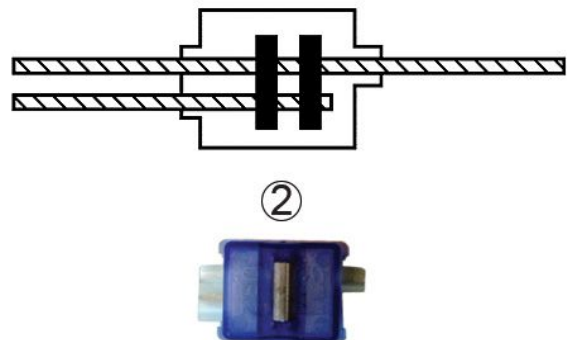
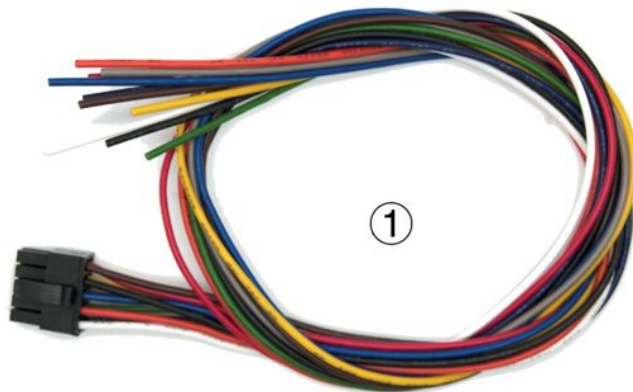

10. Outputs and inputs

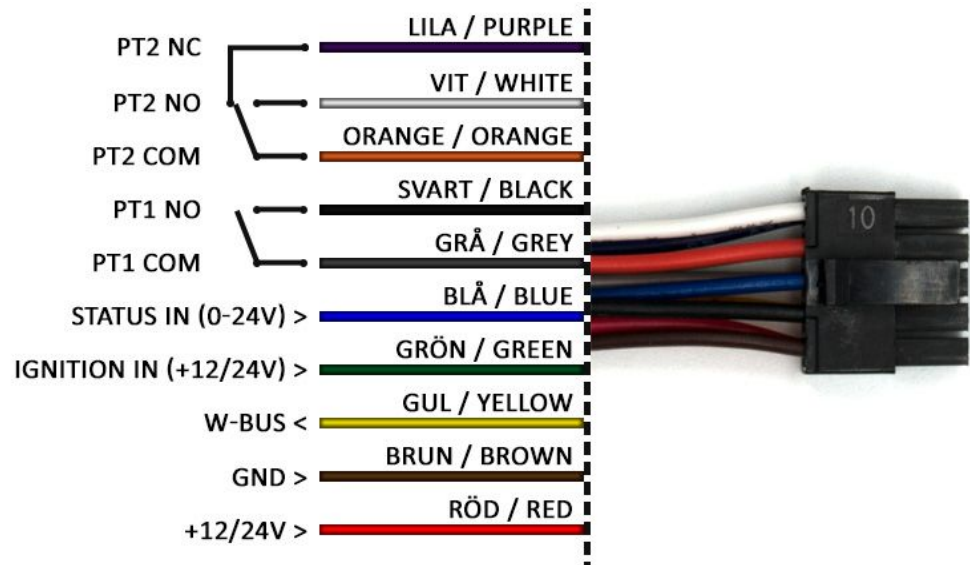

PT*

These are potential free output. "PT1" and "PT2" is controlled at the same time! Max **500mA** each. Protected by built in self resettable PTC fuses.

STATUS IN

Only used in conjunction with some controllers.

IGNITION IN

This can be connected to a source that feeds +12V/24V when the ignition key is turned on. This is used to turn off the preheater when you start the vehicle. This is useful if you need the vehicle earlier than the time you have set the preheater to run.

W-BUS

This is used to control some Webasto heaters.

GND

This is the unit's power supply negative (-). Connect this to the vehicle chassis or battery negative.

+12/24V

This is the unit's power supply positive (+). Connect this to the battery positive.

11. Pushbutton



If the unit is connected to an existing controller the pushbutton is not needed because manual start/stop can be achieved on the controller. Pushbutton sold separately.

PUSHBUTTON



Pushbutton is used to manually control the heater without phone.

MOUNTINGHOLE

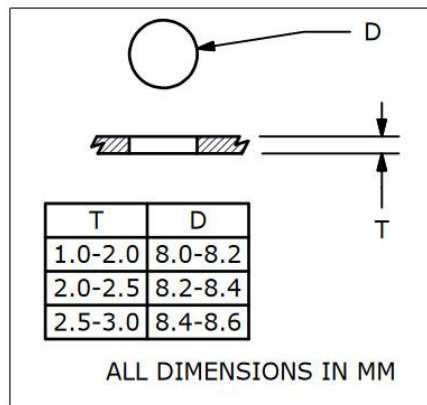

First install the pushbutton and mount contact housing after because it will not fit in the hole.

PIN ORIENTATION

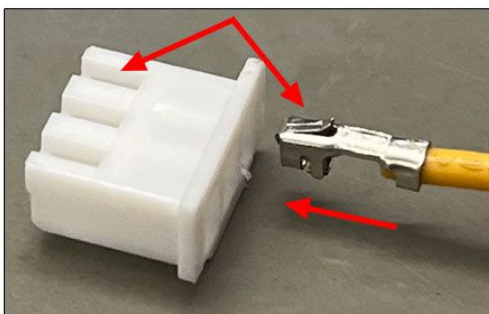

PIN-OUT

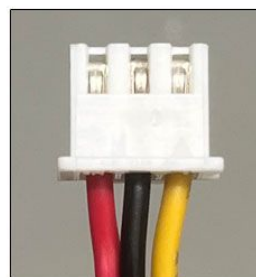

12. Power on



If the STA light don't change to green after about 5 minutes, something is wrong!

Make sure the SIM-card is activated and the **PIN-code is disabled**.



The STA light is also used to indicate if the heater is on or off!

After the unit is connected the "STA" light should directly light up red.



Then it should turn off after a couple of minutes.

When the light is turned off the unit is connected and ready to communicate with!



13. First test



The commands are not case-sensitive!

If the unit does not reply something is wrong, check balance, spelling and phone number!

First make sure the "STA" light has turned off after connecting power!

Now you need to configure the unit to what it is connected to by sending the SMS at the bottom of the supplied schematic. Below follows an example for universal connection.

| | |
|---------------|--|
| PH | Start prefix for the command. Letters. |
| 0000 | Password (default four zeros) |
| OPMODE | Letters |
| 1 | Digit one. This differs between different schematics. |

The units should respond "OPMODE SET OK" and then the "STA" light should come on again.

PH0000OPMODE1

OPMODE SET OK, NOW REBOOTING. PLEASE WAIT 2 MINUTES.

When the light has turned off again the unit is configured!

14. Use the APP

If the unit replied to the previous command everything is working correctly. Now it is easiest to use the mobile APP instead that is available for iPhone and Android.

If you want to be able to start the heater by phone call you first need to add (max 5) your phone number to the units memory. This to prevent anyone from starting the heater when calling.

Use the command "ADD USER" i the app.

The APP can be downloaded in Appstore and Google Play, search for "GSMS remote control".

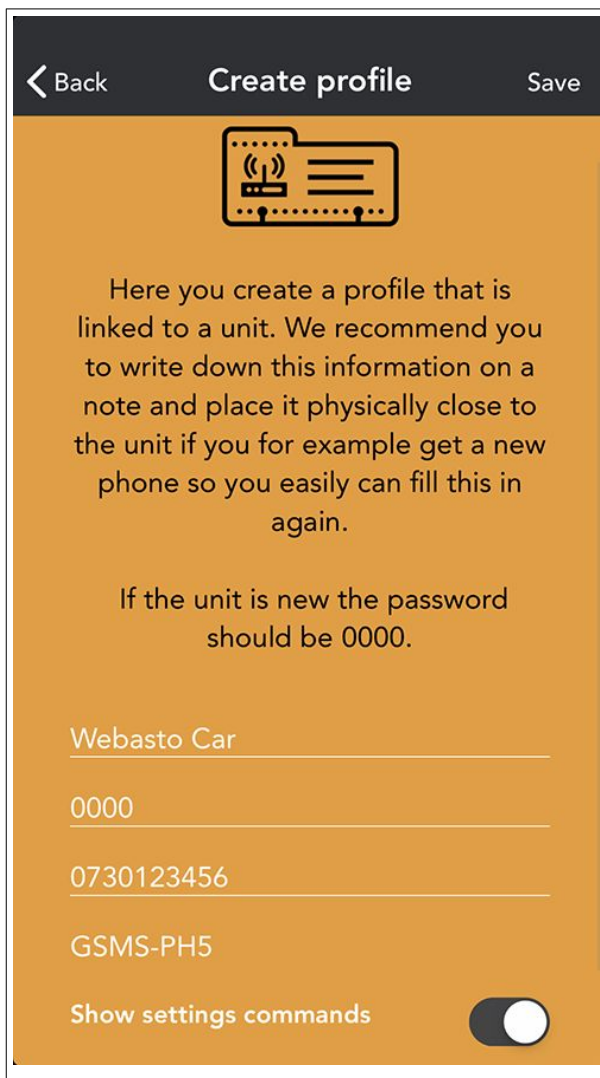

Start by creating a "profile" that is associated with the unit.

Everything that is typed into the app is only saved locally on the phone which means that if you change phone this needs to be filled in again.

It is therefor recommended to take a screenshot of what is typed in "profile" and save this image for future reference.

In the first field type a name for the unit to easily identify the unit.

Second field is password, type four zeros because the unit is new.

Third field is the phone number to the installed SIM-card.

Choose "GSMS-PH5" in the list.

Check "Show settings commands" to display all commands in the APP. After the unit is configured this can be unchecked to hide all settings commands.

15. All commands



When controlled via SMS a four digit password is used (by default four zeros).

Every command starts with prefix "SW" followed by the four digit password.

Don't use any spaces or other characters other than the ones described. Commands are nor case-sensitive but for clarification all commands below are written in uppercase.

All default settings are marked with underscore ex. **TIMER030M**

| # | SMS Command | Description |
|---|--|---|
| 1 | PH0000CP1234 | Changes the password from "0000" (default) to for example "1234"; this new password "1234" will be used in the following examples. |
| 2 | PH1234CHECK | This command requests an "Overview SMS" from the unit containing status of the heater as well as temperature and signal strength. |
| 3 | PH1234SETTINGS | Returns an SMS with information about the heattime etc. |
| 4 | PH1234ON ... OFF | Commands to turn the heater on or off. |
| 5 | PH1234ONF00H01M ... ONF99H99M | Turns on the heater into the future. Please note that you always need to specify both hours and minutes to turn on as the format to the left. |
| 6 | PH1234ONF0 | Cancels a scheduled start. Note last character is a zero. |
| 7 | PH1234TIMER010M ... <u>TIMER030M</u> ... TIMER999M ... TIMER000M | Set up how long the heater should run. This setting has affect every time the heater is turned on using both SMS and phone calls except when using the command below. The format must always be 3 digits. For continues operation use three zeros! |

| | | |
|----|---|---|
| 8 | PH1234ON010M . . . ON999M | <p>Turns the heater on but overrides the timer-setting. For instance if the timer is set up at 60 minutes but you want to turn the heater on for 20 minutes one time only.</p> <p>The format must always be 3 digits.</p> |
| 9 | PH1234U1A11111 . . . U2A22222 . . . U3A33333 . . . U4A44444 . . . U5A55555 | <p>This command adds a phone number that should be authorized to control the heater with phone calls. When the unit is controlled with SMS this have no effect as SMS control uses a password instead.</p> <p>These are also the numbers that will be receiving important system SMS alerts. Up to 5 authorized users can be added, users 1-5 (U1-U5).</p> |
| 10 | PH1234U1A0 . . . U2A0 . . . U3A0 . . . U4A0 . . . U5A0 | <p><i>Erases phone number in memory "U1", "U2" ... "U5".</i></p> <p>Note last digit (0) = zero.</p> |
| 11 | PH1234AUTHLIST | <p>Returns a SMS with a list of all authorized phone numbers.</p> |
| 12 | PH1234SMS0 . . . <u>SMS1</u> | <p><i>This configures if the unit should send back verification SMS when changing settings and controlling the relays.</i></p> <p>SMS0 = Disables verification SMS. SMS1 = Enables verification SMS.</p> |
| 13 | PH1234RESETDATA | <p>Erases all data and returns the unit to factory default.</p> |

| | | |
|----|--|--|
| 14 | <p>PH1234RMOM0 . . . RMOM1 . . . RMOM2 . . . RMOM2 RMOM9</p> | <p>This command configures the outputs to switch on momentary and can be used if for example the potential free output has been connected parallel to a switch that starts the button when pushed momentarily.</p> <p>RMOM0 Normal mode.</p> <p>RMOMX Momentary mode 1-8 seconds. Replace "X" with 1-8.</p> <p>RMOM9 Momentary mode 500ms (0.5 second).</p> |
| 15 | <p>PH1234OPMODE1 . . . OPMODE2 . . . OPMODE3 OPMODE9</p> | <p>This sets up the unit in different operational modes depending on what controller is used. More information in the seperat supplied schematic.</p> <p>OPMODE1 Universal mode.</p> |
| 16 | <p>PH1234SMSRESET</p> | <p>The unit will monitor the number of SMS sent within an hour. If the unit should send more than 20 SMS in an hour it will not allow any more SMS to be sent before this command is sent to the unit.</p> |

16. Support

www.otacell.se

Phone: +4635 - 10 09 44

E-mail: info@otacell.se

17. Troubleshooting

The unit does not connect, "STA" light remains red.

Check that the SIM-card is activate and that the PIN code is **disabled**.

The unit does not reply to commands.

Check that the SIM-card has balance and that it supports SMS. Also check that the phone number you are sending the commands to are correct!

After changing the SIM-card the unit don't respond.

Every time a SIM-card is replaced the unit must be restarted by turning of the power. It is also possible to wait approximately 30 minutes and the unit will automatically detect the change.

When calling the unit ring tones can be heard but relay 1 don't change state.

Make sure you have added your phone number to the authorized list of users in the units memory. See "ADD USER" in the app.

I have forgotten my 4-digit password.

If you have lost or forgot the 4 digit password used to control the OTAC-PH5 via SMS you will need to have physical access to the unit to do a hardware reset as described below.

1. Unplug the unit from the connection cable.
2. Next plug it in again and roughly **5 seconds after it is plugged in**, connect "IGNITION IN" (GREEN WIRE) to +12/24V and leave connected until "STA" LED starts flashing.

"STA" light remains off when power is connected.

Make sure correct voltage is supplied and that positive and negative poles are connected correctly.

How do I check how much money I have on the installed pre-paid SIM-card.

Please talk to your SIM-card provider. Generally you can add money online and with most providers you can also register the SIM-card and monitor it online.

"STA" is flashing.**If the "STA" LED is flashing it is an indication that something is wrong.**

If the LED is flashing rapidly (multiple times a second) the unit cannot recognize the SIM-card. Try a different SIM-card!

Instead if the LED is flashing every second there is a PIN-code on the SIM-card. Please disable it!

Is it flashing every fourth second the unit cannot connect to the network. This could be an indication that insufficient coverage in the area. Please move the unit to another location or try another network operator.

Den senaste versionen av denna manual kan hittas här:

https://otacell.se/otac_ph5_h01a_eng_manual.pdf

